

Montage du panneau solaire / Solar panel installation / Montage Solar Paneel

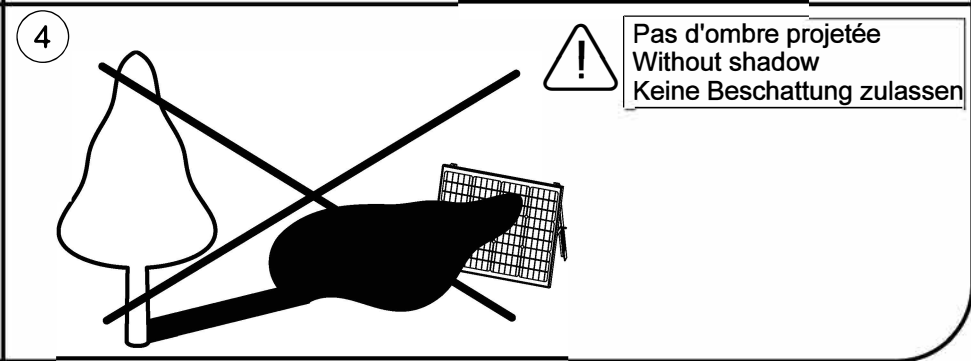

Raccordements en eau / Water connections / Wasseranschlüsse

1

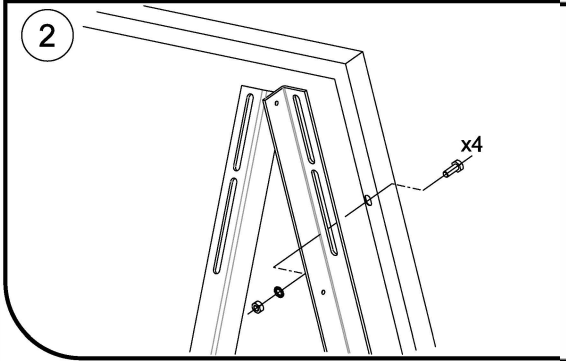
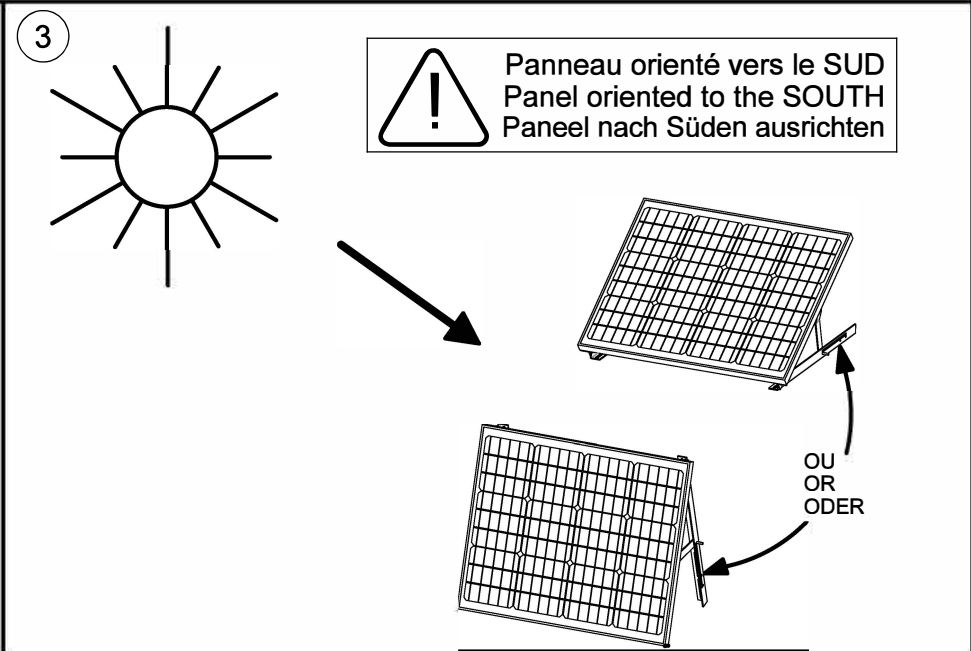
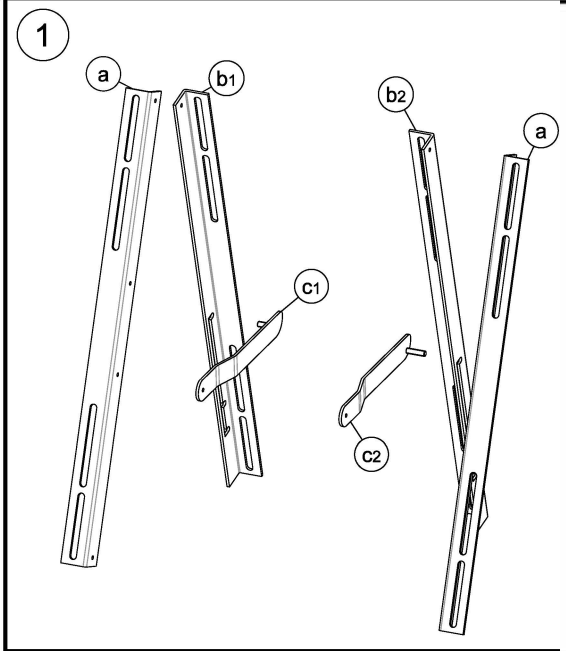
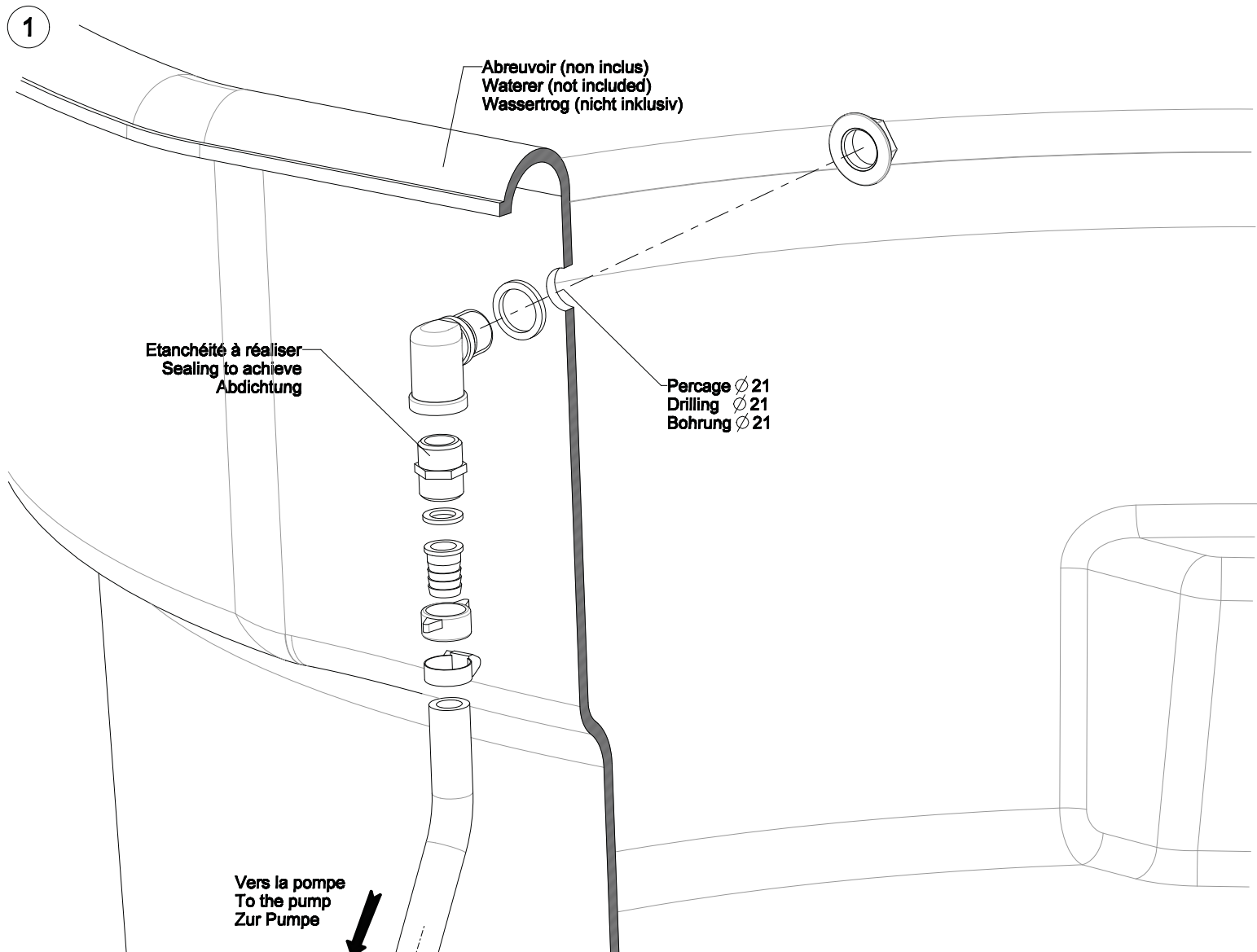

2

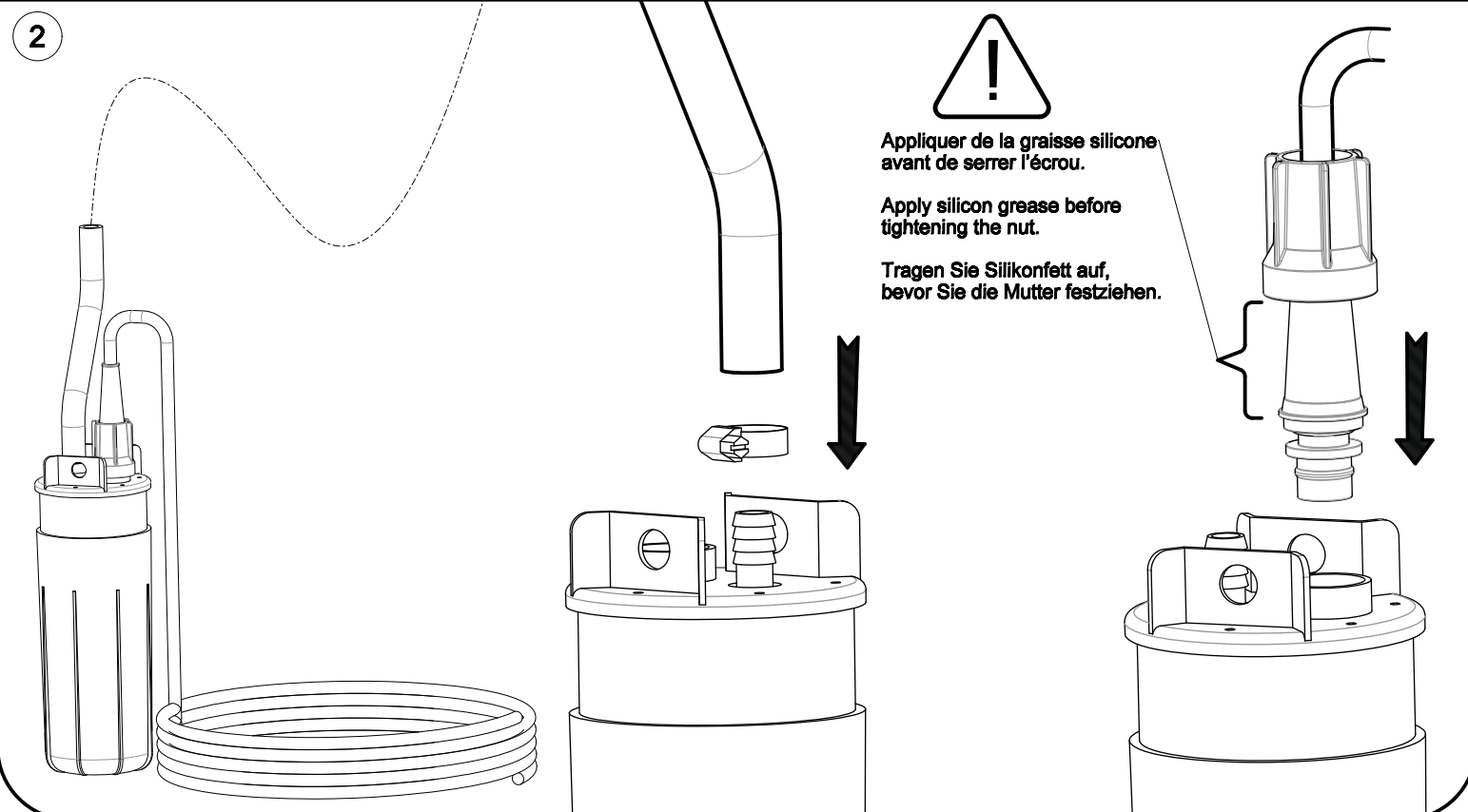

Raccordement de l'interrupteur à flotteur / Float switch connection / Anschluss des Schwimmerschalters

1

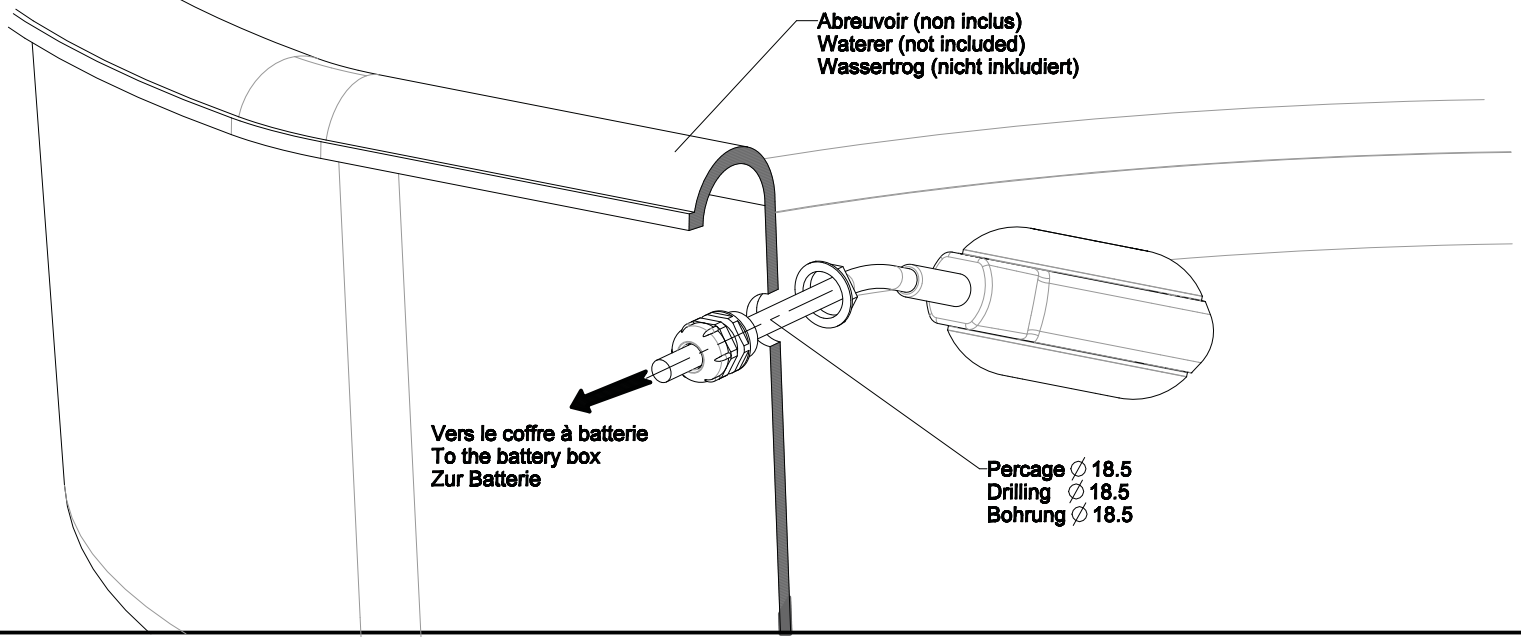

2



Protéger le flotteur des animaux
Protect the float from livestock
Schutz des Ventils vor den Tieren

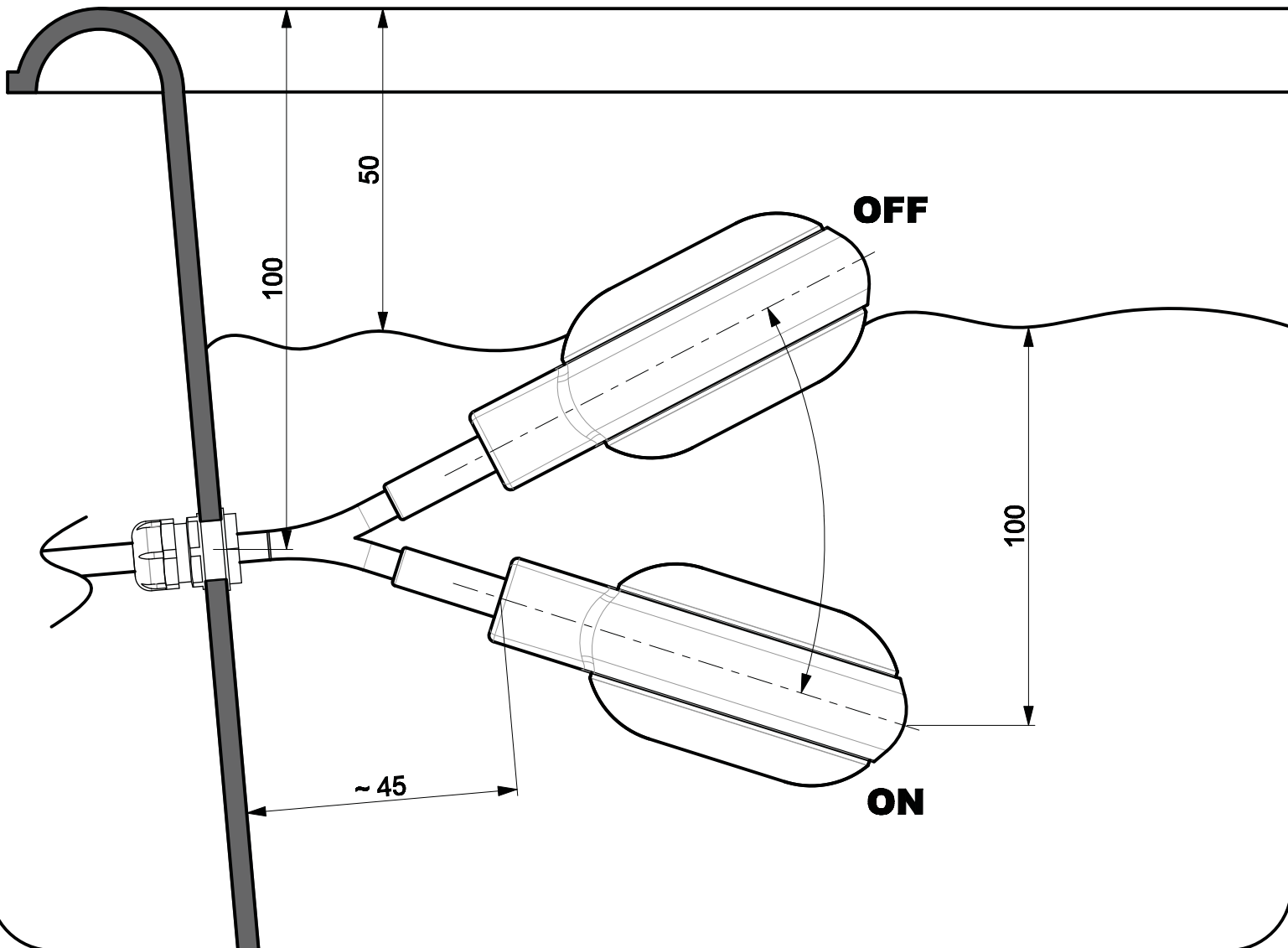

Raccordement de l'interrupteur à flotteur / Float switch connection / Anschluss des Schwimmerschalters

3

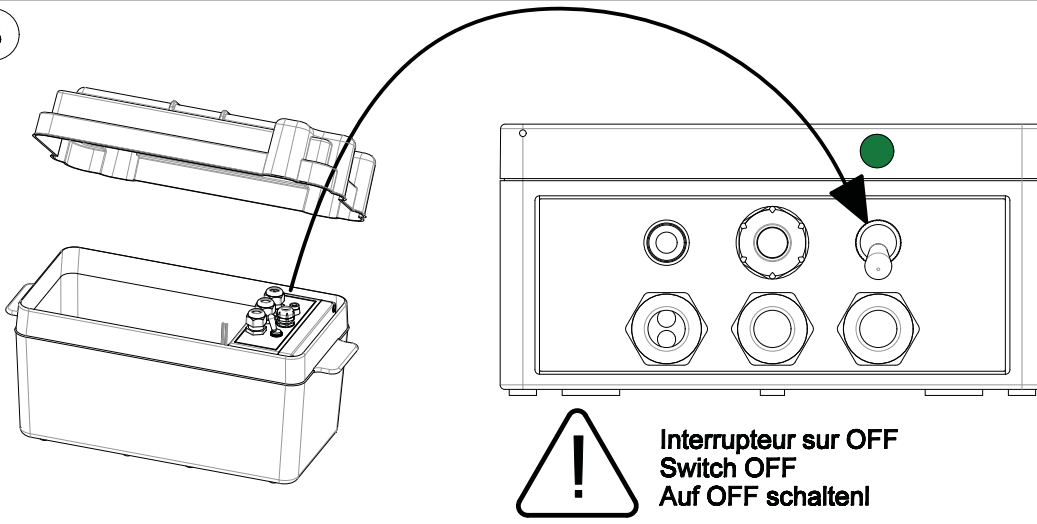

4

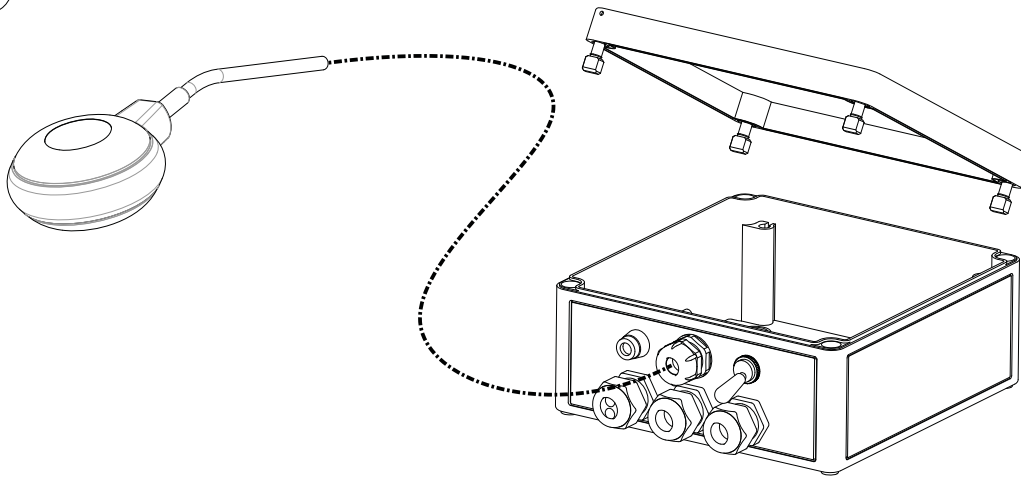

5

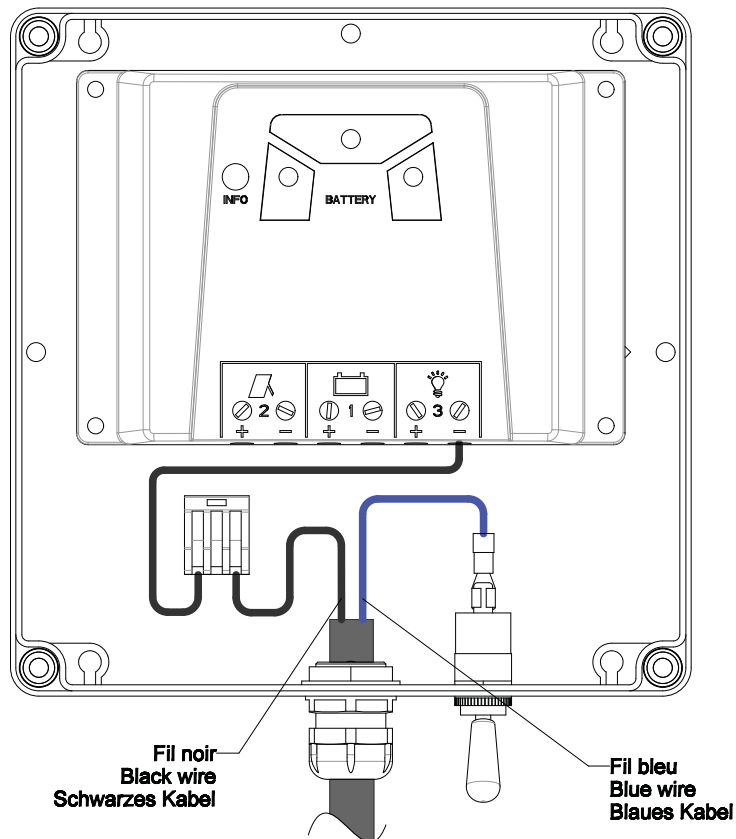

Raccordement de la pompe / Pump connection / Anschluss der Pumpe

1



-Ne pas manipuler la pompe par le câble électrique.
Utiliser un filin (non fourni)
- Don't handle the pump by power wire.
Use a rope (not included)
- Ziehen Sie nicht am Elektrokabel.
Benutzen Sie ein Seil (nicht inkludiert)

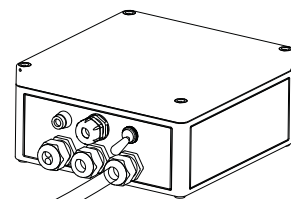
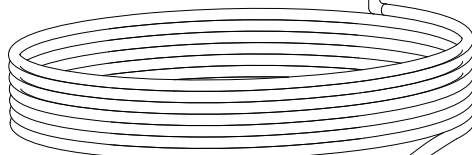
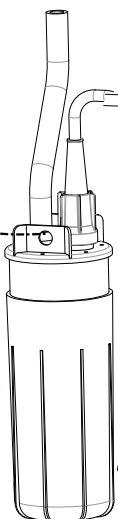

Vers la pompe
To the pump
Zur Pumpe

Vers le coffre à batterie
To the battery box
Zur Batterie

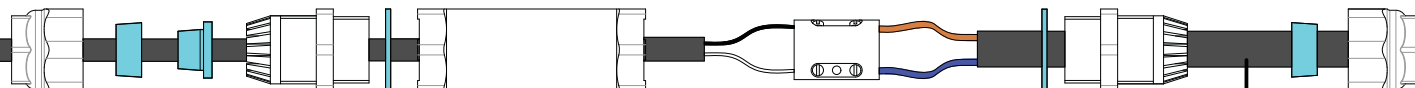

Ne pas utiliser
Don't use
Nicht nutzen

2

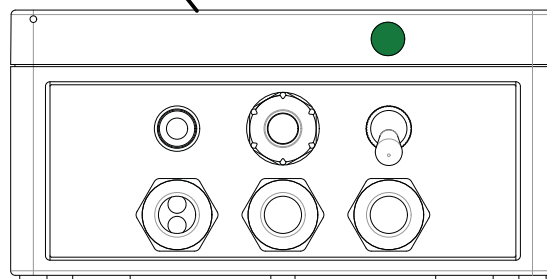
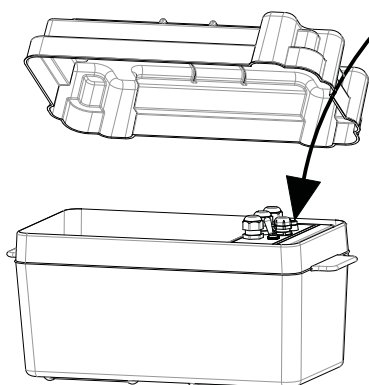

Raccordements de la batterie / Battery connection / Anschluss der Batterie

1

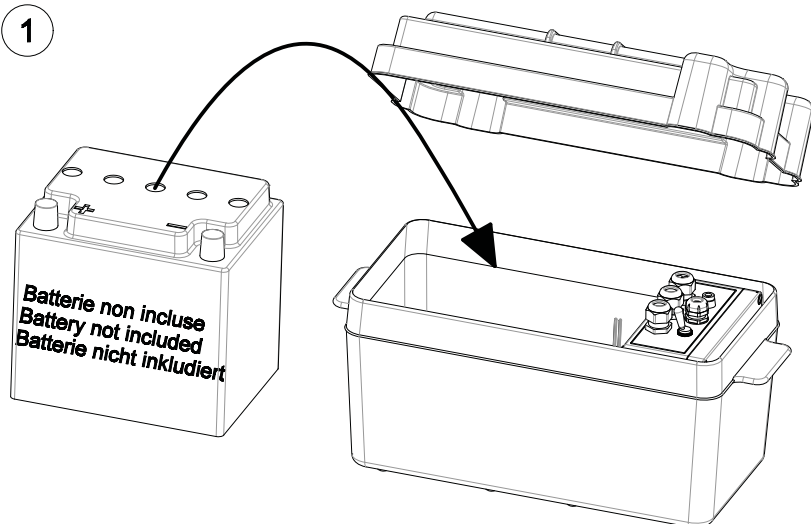

-Pour des performances optimales nous vous suggérons l'utilisation d'une batterie compatible panneaux solaire.
Type = 12V-85 Ah / Dimensions = 280 x 175 x H 190
-To guarantee the optimal performances we advise you to use a solar battery.
Type = 12V-85 Ah / Dimensions = 280 x 175 x H 190
- Um eine optimale Funktion zu garantieren, empfehlen wir folgende Solar Batterie.
Typ = 12 V - 85 Ah / Abmaße : 280 x 175 x H 190

2

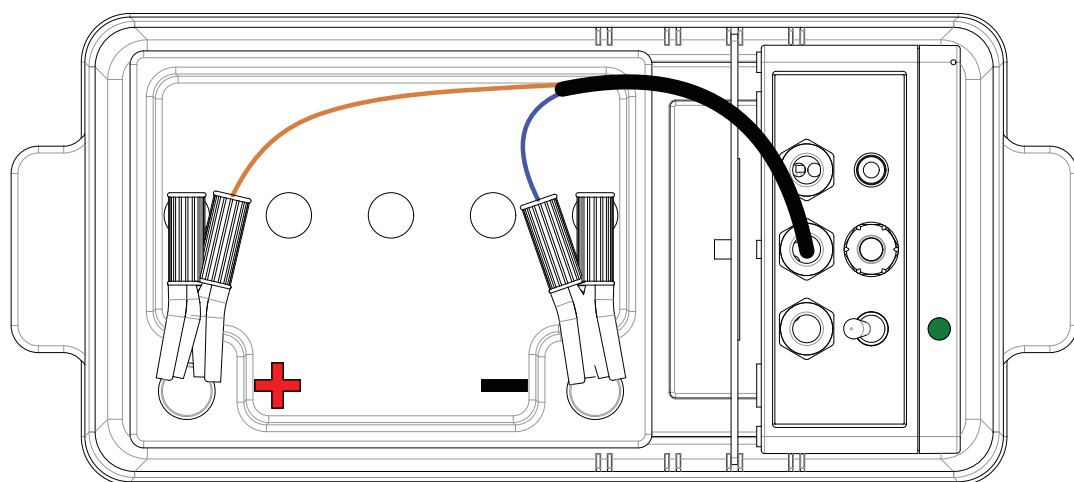

3

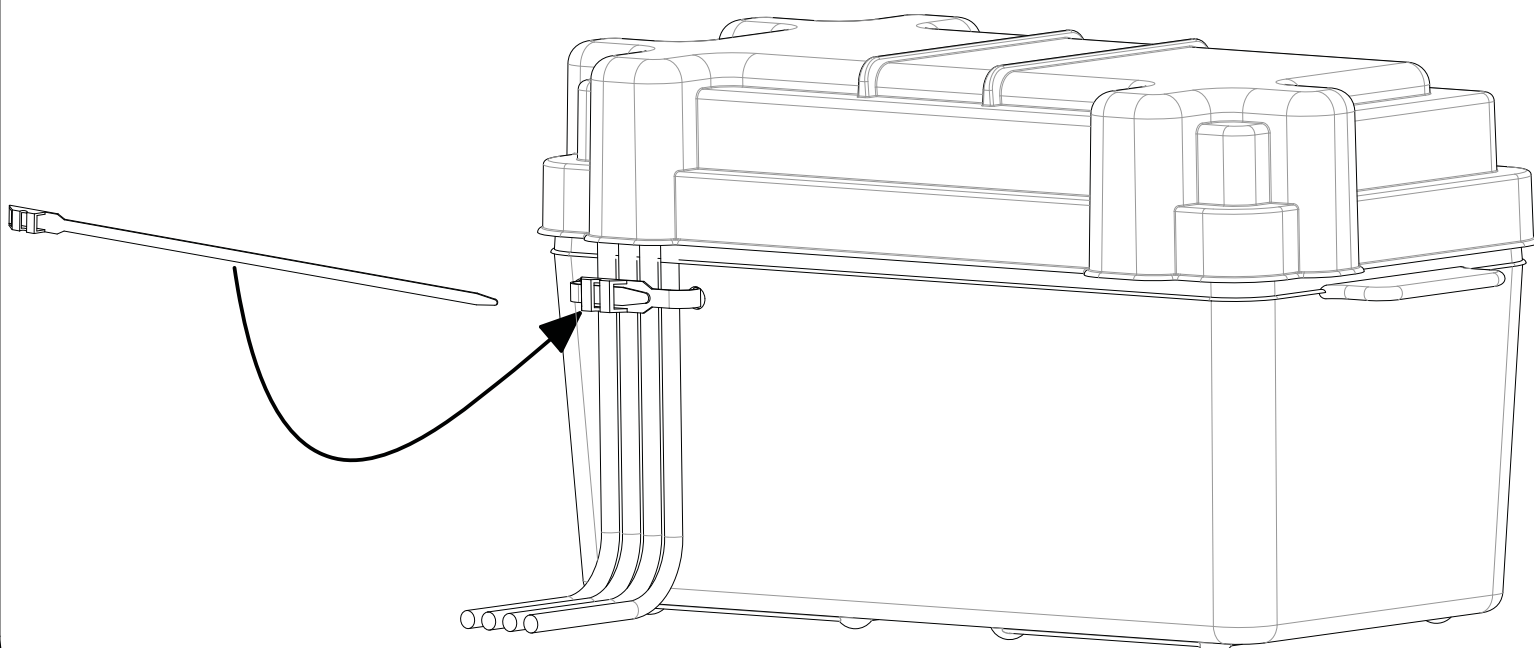

Raccordement du panneau solaire / Solar panel connection / Anschluss Solar Paneel

1



Couvrir le panneau avant de le connecter
Cover the panel before connection
Bedecken des Paneel vor Anschluss

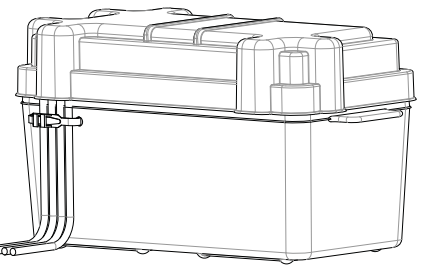
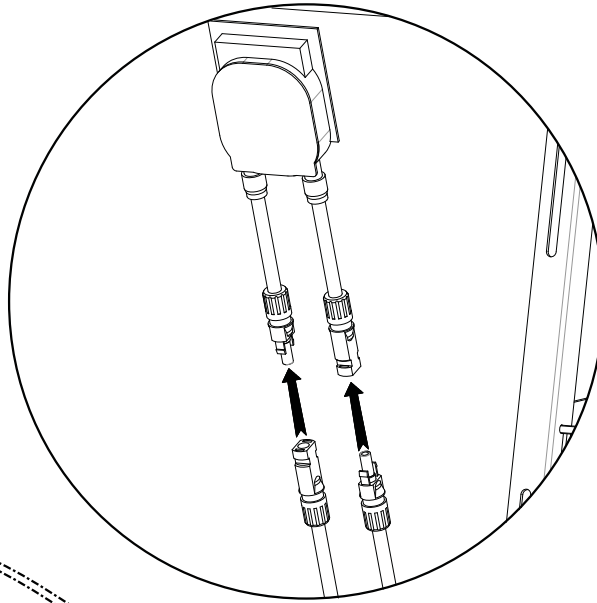
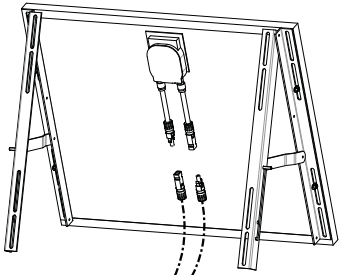

Test de fonctionnement / Check serviceability / Prüfen der Funktionsfähigkeit



Interrupteur sur ON (vert)
Switch ON (green)
Schalten auf ON (grün)

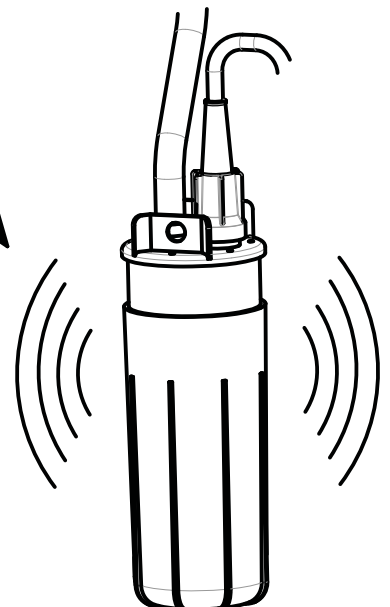
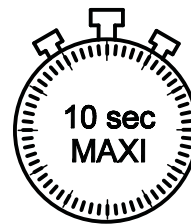
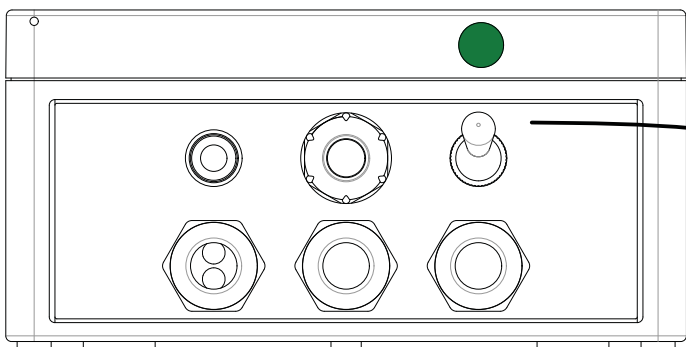

Installation / Set-up / Installation

